

# The Try Stick

Mors Kochanski

The purpose behind the try stick is to practice and demonstrate the skillful use of the knife as a wood carving tool, as well as to learn some of the practical operations that may be used in wilderness living.

Some of the carving operations may be of very practical application, others are meant to tax the skill of the carver and some may be used for decorative purposes.

## SUITABLE CARVING WOOD:

Any straight-grained, knot-free wood will do for the stick with one of the better woods being a straight piece of willow [*Salix*]. Although it may be used green the willow is at its best if it is peeled and dried. A stick two to three centimetres in diameter and armpit to fingertip long may accommodate most of the carving operations.

## SHARP KNIFE MANDATORY:

Implicit in the making of a try stick is a knife sharpened to the minimal degree of sharpness for working with wood [See pages 14 to 22, Vol. 2, No. 2]. Also the safe use of the knife should be reviewed in the same issue on pages 10 to 12.

## KEEPING THE WORK CLEAN:

A properly executed try stick should be free of grime. Wash the hands before each carving session and leave the operations slightly unfinished until all are done and then carry out the finishing touches to clean wood.

## EFFICIENT DESIGN:

Although the imagination may run rampant as to what might be carved on the try stick, it may be wise to learn how to carve the useful operations efficiently and quickly. It should take less than a minute to carve a pot hook, for instance. The hook should also be so well made that there is little chance that the bail of a pot will slip out of it or the hook split off as might happen if it is made too near the end of the stick.

## CUTTING THROUGH A STICK:

One of the more basic operations is cutting through a stick. Small cuts at about a 45 degree angle are made completely around the stick and repeated if the stick is quite thick. If your wrist is weak then this step may be repeated as many times as necessary until about one third of the stick

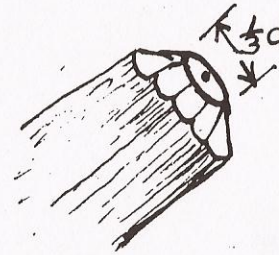
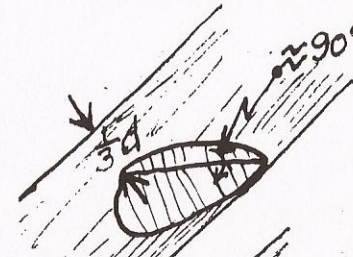

Figure 1. Trimmed end of stick.

is left. The stick is then broken over the knee or by giving it a sharp rap on a log. The remaining fracture is trimmed off neatly.

## THE POT HOOK:

The hook should not be carved any closer to the end than three or four centimetres or it may split off in use. The throat of the hook should take up about two thirds of the stick.



Repeat the mirror image of this but on the other side.

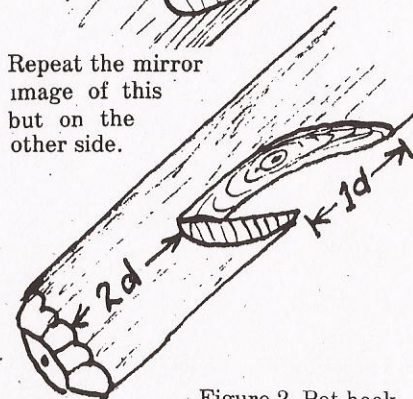

Figure 2. Pot hook.

## THE ROUND NOTCH:

This notch may be used in building the Roycraft "A" packframe [Vol. 1, No.4 page 10 to 20]. It is one of the simplest common notches in round log buildings. The notch should be the same diameter as the stick, going half way through the stick, and be perfectly round.

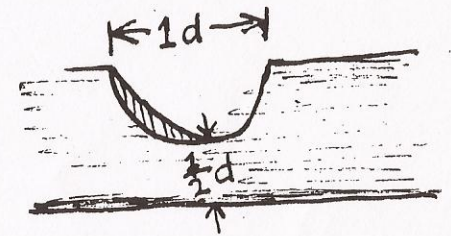

Figure 3. The round notch.

## THE SADDLE NOTCH:

This notch is commonly used in log building. It is easily expedited with an axe as no curved cuts have to be made.

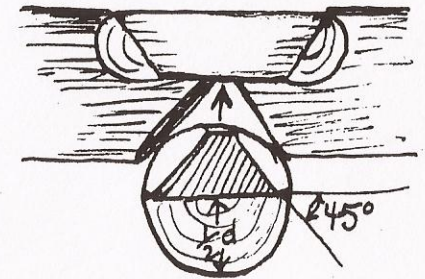

Figure 4. The saddle notch.

### THE SQUARE NOTCH:

This notch is used in a special sense in log building. It might be used for the first logs laid down and for the last logs to complete the walls as it resists moving or rolling. In log construction the notch may be made as shown to achieve a natural appearing fit. For the purposes of the try stick the notch may be simply rendered as shown. It should go half way through the stick and all angles should be 90 degrees.

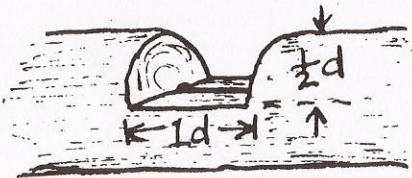

Figure 5a. The square notch in log construction.

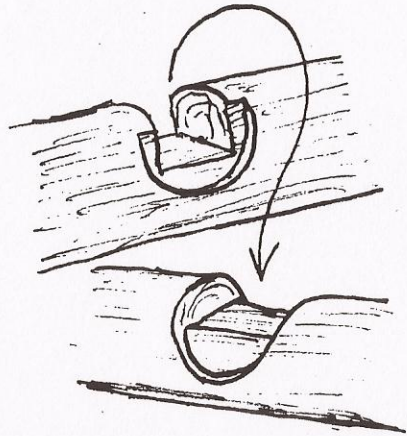

Figure 5b. The ordinary square notch.

### THE MITRED LAPPED NOTCH:

This is a notch used in decorative and detailed work in log construction. It can also be used with the upright stick of the Figure 4 deadfall trigger. The notch is nothing more than squaring the round stick. The flattened faces of the notch may be multiples of the diameter of the stick.

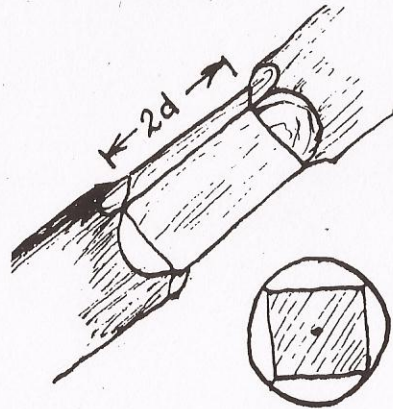

Figure 6. The mitred lapped notch.

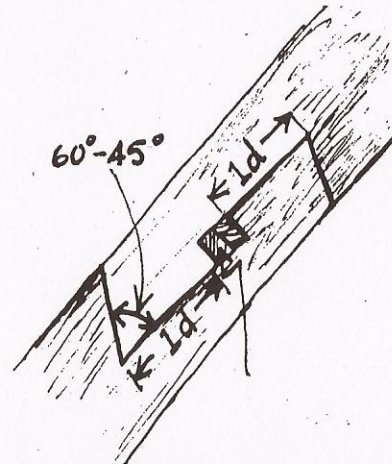

Figure 7. The jogged and wedged splice.

### THE JOGGED AND WEDGED SPLICE

This operation exemplifies the splicing of logs end to end. There is considerable latitude to the angles used. 60 to 45 degrees is recommended for the purposes of this carving.

### THE DOVETAIL PIN AND SOCKET

This is a method of joining one stick to another at 90 degrees for a variety of applications.

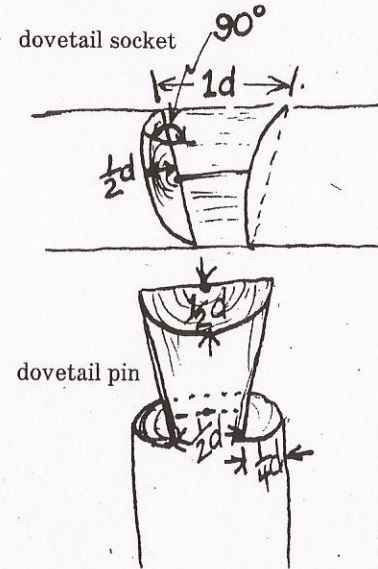

Figure 8. The dovetail pin and socket.

### THE DOVETAIL NOTCH:

This notch should go half way through the stick. You may carve the notch first and then fit the pin to suit. It is more difficult doing it the other way around. Start by cutting a narrow "V" notch and then extend it into the dove tail.

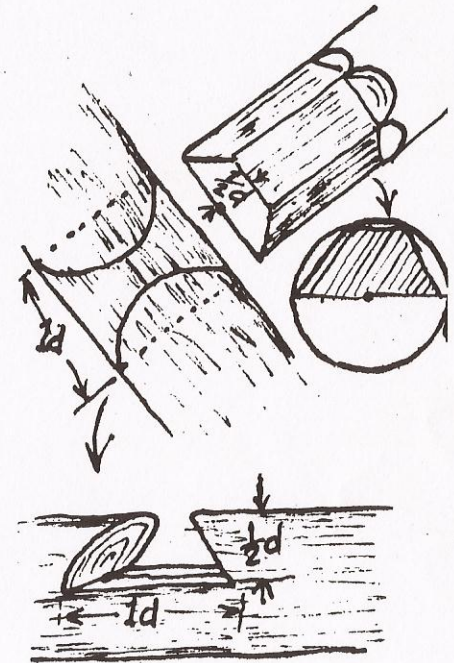

Figure 9. The dovetail notch.

### THE "V" NOTCH:

The opening of the "V" should be the diameter of the stick and the notch should go halfway through the stick.

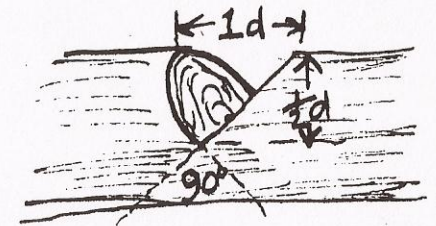

Figure 10. The "V" notch.

### THE SPEAR NOTCH:

This notch is used for fitting an arrow head or spear point on a shaft, for making the Bow String notch on an arrow, for making a netting needle [use a green willow and tie the notch shut until it is dry], and many other applications. "V" notches "a" and "a-1" opposite each other should not be any deeper than one third of the diameter of the stick or the stick will break from "a" to "a-1". The shallow notches "b" and "b-1" should be made to a depth of about one quarter of the stick. With the knife tip cut the fibers 90 degrees to their grain and as deep as possible. The stick is then laid on a flat surface supported at the general region of points "b" and "b-1" as shown in the figure, and given sharp blows with the hand or a stick, gradually increasing the force until a snap is heard. The stick is turned over and the process repeated to break out the other side of the notch. The stick is then worked back and forth to further loosen it, and the notch is then broken out.

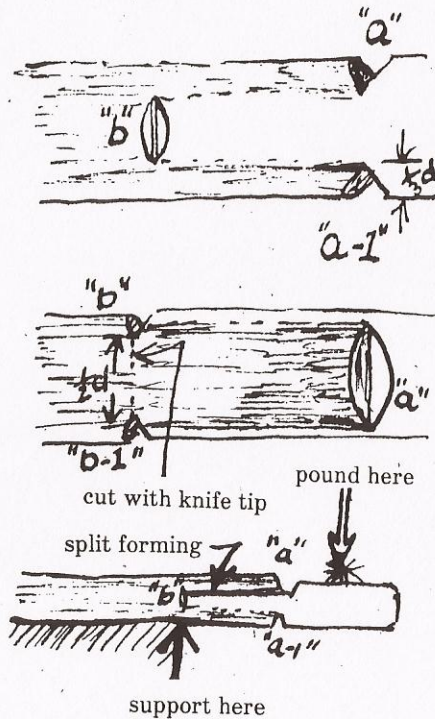

Figure 11. The spear notch.

### THE KNIFE TIP MORTICE:

[Hole Through Stick]. Whenever a hole through a stick is wanted and the knife is the only available tool to make it with, the following procedure is used. The stick first has to be thinned down. If you do not thin the stick down enough you will have difficulty in making a hole through it with the knife, and if you make it too thin the stick may be too weak for your purposes. The easiest way to make the hole is to make it square or rectangular by cutting the fibers at 90 degrees from both sides and prying the chips out. Trying to drill a round hole with a

knife tip usually results in a fuzzy mess. The hole through the stick is used in the bow for the fire drill [Vol. 1, No. 6, page 31], for choke bars in some snares, and for constructing the ojib-way bird snare.

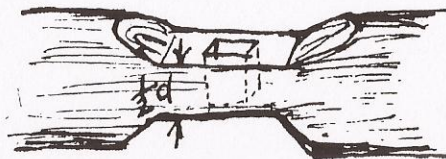

Figure 12. The knife tip mortice.

### DIAMETER REDUCTION:

This operation is simply reducing the diameter of the stick. Leave one half of the diameter of the stick remaining or it may be unduly weakened. The width of the reduction should be about the diameter of the stick. One direct application of the reduction is for the central portion of a toggle.

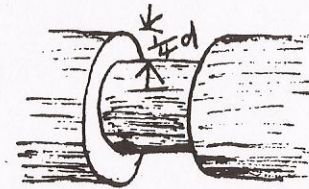

Figure 13. Diameter reduction.

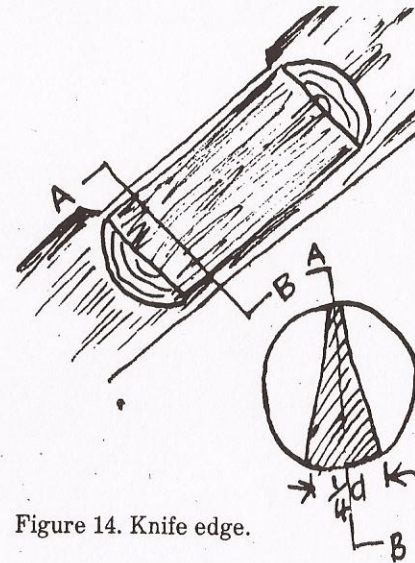

Figure 14. Knife edge.

### THE KNIFE EDGE:

This operation, in combination with the split end of a stick, does away with the necessity of using a forked stick in

cooking cranes and certain deadfall traps. The thickness remaining is about one quarter the diameter of the stick.

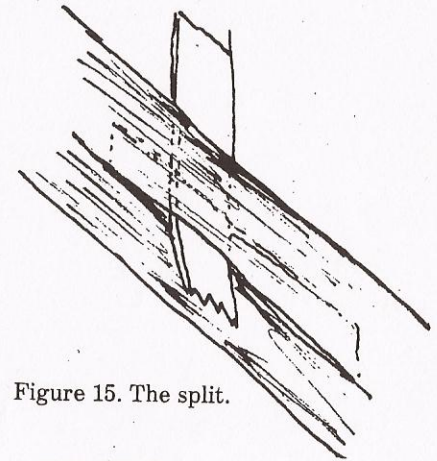

Figure 15. The split.

### THE SPLIT:

This operation is simply splitting the stick in its central portion by driving the knife through it. A chip or piece of bark is put in the split to prove it has been done. This operation has a variety of applications such as in basket weaving, fletching primitive arrows, and making pot hooks.

### ROOT STRIPPER:

The root stripper is a tool used to remove the bark from spruce roots. It is simply a sophisticated split that allows easy insertion of the root to be stripped. The use of this tool is illustrated in Vol. 1, No. 6, Page 53.

### THE BOW NOTCH:

This is the notch used in connection with attaching a bow string to the limbs of a bow. This notch is a shallow form of pot hook.

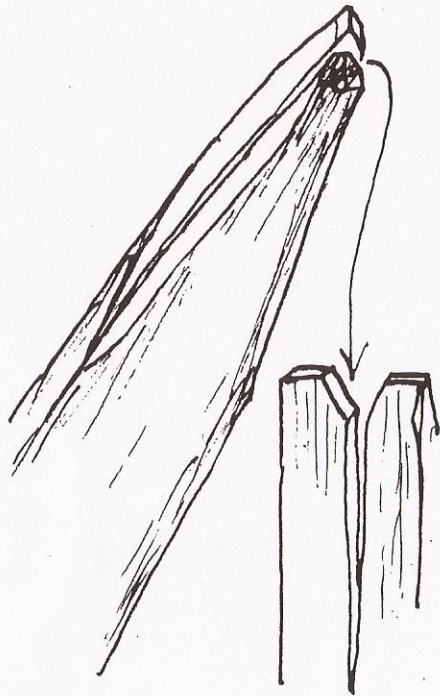

Figure 16. The root stripper.

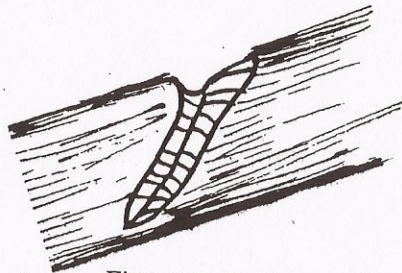

Figure 17. The bow notch.

**THE LATCH NOTCH:**

This notch is used in connection with some deadfall trigger mechanisms. The notch should go about half way through the stick.

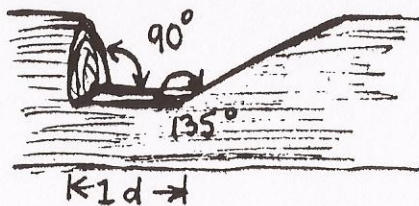

Figure 18. The latch notch.

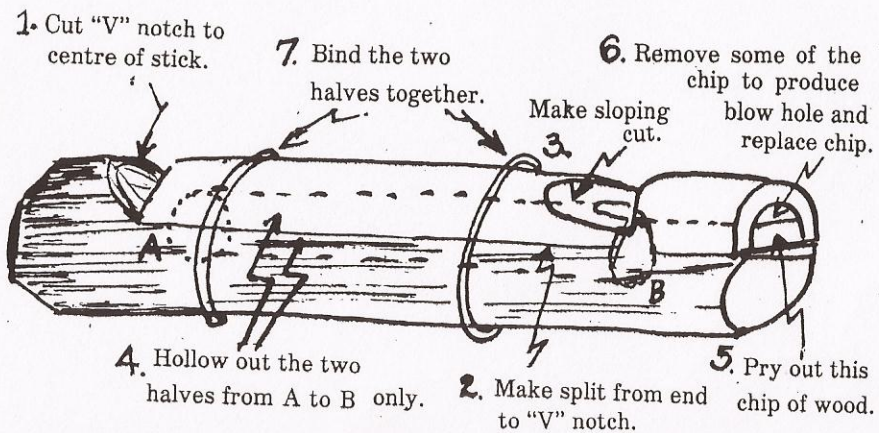

Figure 19. The whistle.

**THE SAMPLE STICK**

**Purpose:** To practice and demonstrate the skillful of pocketknife.

The operations either represent some useful application, or in themselves require skill to carve with the knife.

The work has to be done with a sharp knife, and the carved wood should not be grubby after you are done.

- (1) End neatly trimmed.
- (2) Reduction- for toggles, packframe construction.
- (3) Pot hook notch.
- (4) Saddle notch - packframe construction.
- (5) Dovetail notch - packframe, cooking crane, deadfall trigger mechanism.
- (6) 90° latch - deadfall trigger.
- (7) Planes 90° to each other, deadfall trigger.
- (8) Split.
- (9) Piece of bark inserted in split.
- (10) Notch for spear point.
- (11) Flute or whistle.

- (12) Bow nock.
- (13) Hole through stick - for bow drill, Ojibway bird snare.

- (14) Stripper to remove bark from spruce roots.

- (15) If the stick used is willow, the bark may first be peeled off, scraped and twisted into cord.

